



Date/Data:

8

e-mail: biuro@itatools.pl

fax: 12 306 79 08

Checklist for modification saw blades / Karta do modyfikacji pił tarczowych

Piła poddawana przeróbce (kod) • Modified saw blade (code)	
Otwór główny • Bore	
Otwory mocujące • Pinholes	$n / d2 / d1$
Stożkowe otwory mocujące • Cuntersunk pinholes	$n / d2 - d3 / d1$
Kliny • Keyways	$n / B \times H$
Modyfikacja zębów (kształt, rzaz) • Modification of teeth (kerf, shape)	
Ilość pił • Quantity of blades	

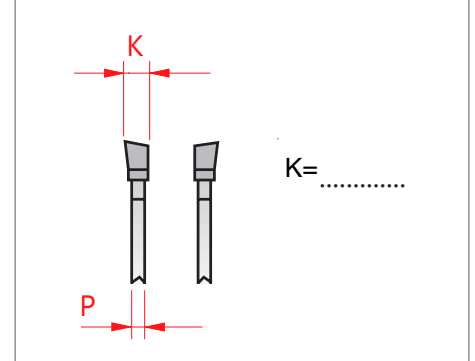
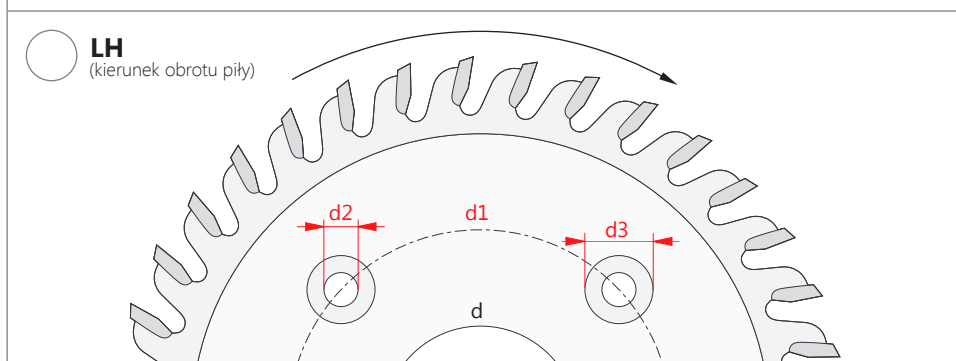
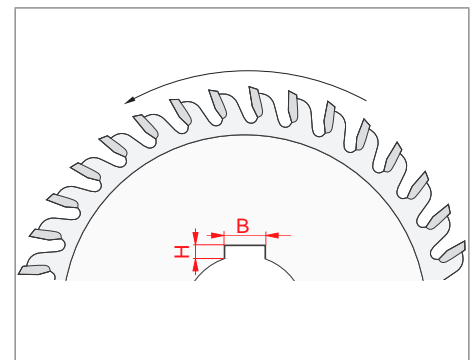
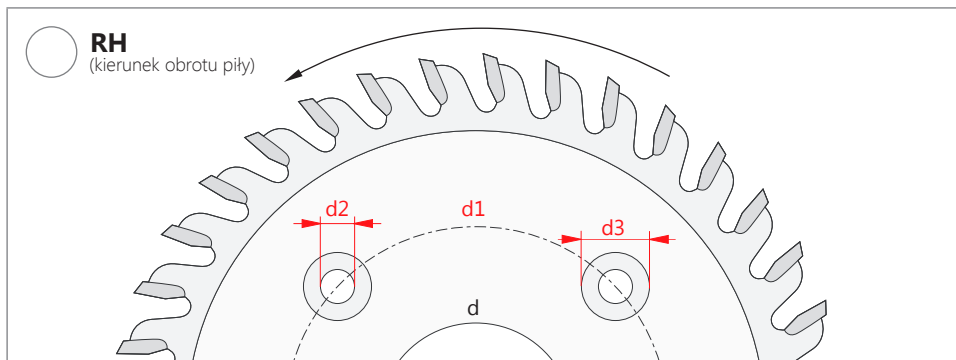

Kształt zęba
• Teeth shape

FZ (PR)	DS (L)	ES (P)	WZ (NS)	TR	HZ	HZ/DZ (ZL)	FZ/TR (TP)	
KON/FZ (T)	KON/WZ (SNS)	EZ/FA	WZ/FA (NSF)	HZ/FA	WZ/WZ/FZ	FZ/FA (FP)	TR/TR (TT)	FZFA/FZFA (TPF)

Handlowiec:

Klient/Numer: