

Checklist for saw blades / Karta dla pił



e-mail: biuro@itatools.pl
fax: 12 306 79 08

Data/Date:	Kod narzędzia:
------------	----------------

<input type="radio"/> Nowe rozwiązanie • New tool/solution	<input type="radio"/> Klient posiada wyceniane narzędzie • Customer has the same tool already	<input type="checkbox"/> Obecny dostawca • Supplier/producer <input type="checkbox"/> Cena • Price
--	---	---

<input type="checkbox"/> Ilość do zamówienia • Single order quantity	<input type="checkbox"/> Potencjał/okres • Estimated product demand	<input type="radio"/> Miesięczny • Monthly	<input type="radio"/> Roczny • Annually
--	---	--	---

<input type="checkbox"/> Maszyna • Machine	<input type="checkbox"/> Materiał obrabiany • Workpiece material
--	--

<input type="checkbox"/> Obroty wrzeciona (obr/min) • Spindle revolution (rpm)	<input type="checkbox"/> Grubość materiału • Thickness of material (mm)
--	---

<input type="checkbox"/> Typ posuwu • Feed type	<input type="radio"/> RECZNY • Manual	<input type="radio"/> MECHANICZNY • Mecanical	<input type="checkbox"/> Rodzaj cięcia • Cutting type	<input type="radio"/> POJEDYNCZO • Single board	<input type="radio"/> PAKIETOWO • Stack of boards
---	---	---	---	---	---

<input type="checkbox"/> Posuw (m/min) • Feed speed (m/min)	<input type="checkbox"/> Rodzaj operacji • Type of processing	<input type="radio"/> ROWKOWANIE • Grooving	<input type="radio"/> CIECIE • Cutting
---	---	---	--

<input type="checkbox"/> Średnica zewnętrzna* D = • External diameter	<input type="checkbox"/> Liczba zębów* Z = • Number of teeth	<input type="checkbox"/> RZAZ* K = • Kerf	<input type="checkbox"/> KORPUS* P = • Body
---	--	---	---

<input type="checkbox"/> Średnica otworu* F = • Bore diameter	<input type="checkbox"/> Rodzaj ostrza* • Tips type	<input type="radio"/> HM • HM	<input type="radio"/> PCD • PCD	<input type="checkbox"/> H =
---	---	---	---	-------------------------------------

<input type="checkbox"/> Otwory dodatkowe* • Pin holes	<input type="checkbox"/> UWAGI: • Adnotations
--	---

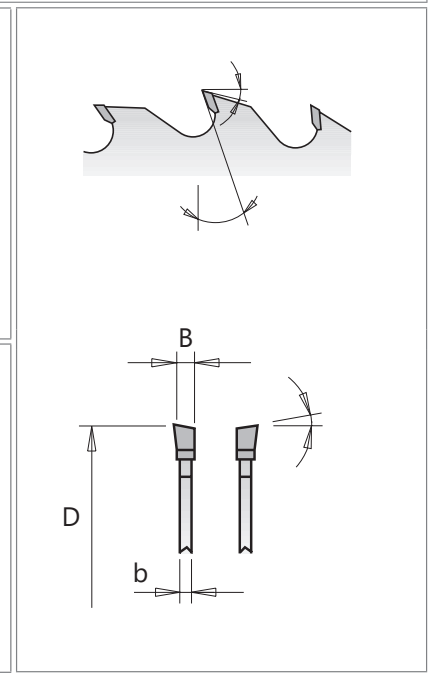
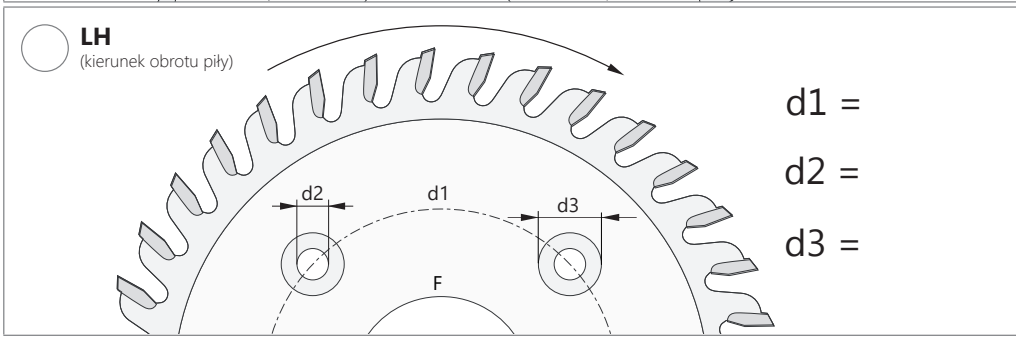
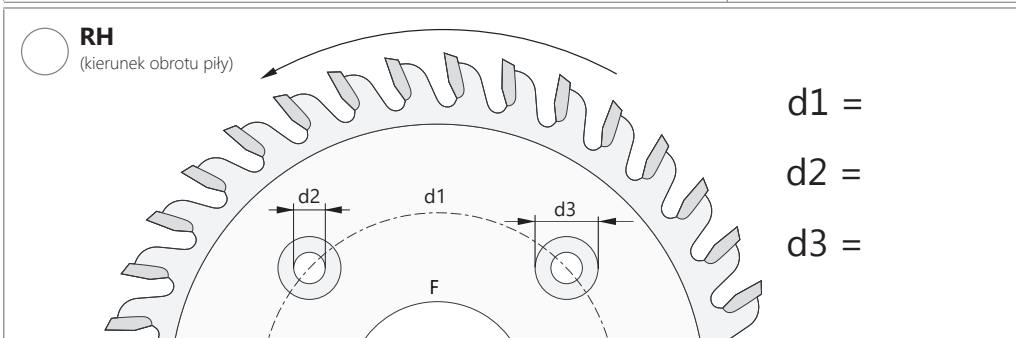

Kształt zęba • Teeth shape									
	FZ (PR)	ES (P)	DS (L)	WZ (NS)	TR	HZ	HZ/DZ (ZL)	FZ/TR (TP)	
	KON/FZ (T)	KON/WZ (SNS)	EZ/FA	WZ/FA (NSF)	HZ/FA	WZ/WZ/FZ	FZ/FA (FP)	TR/TR (TT)	FZFA/ FZFA (TPF)

Handlowiec:	Klient/Numer:
-------------	---------------